

Wall Mount

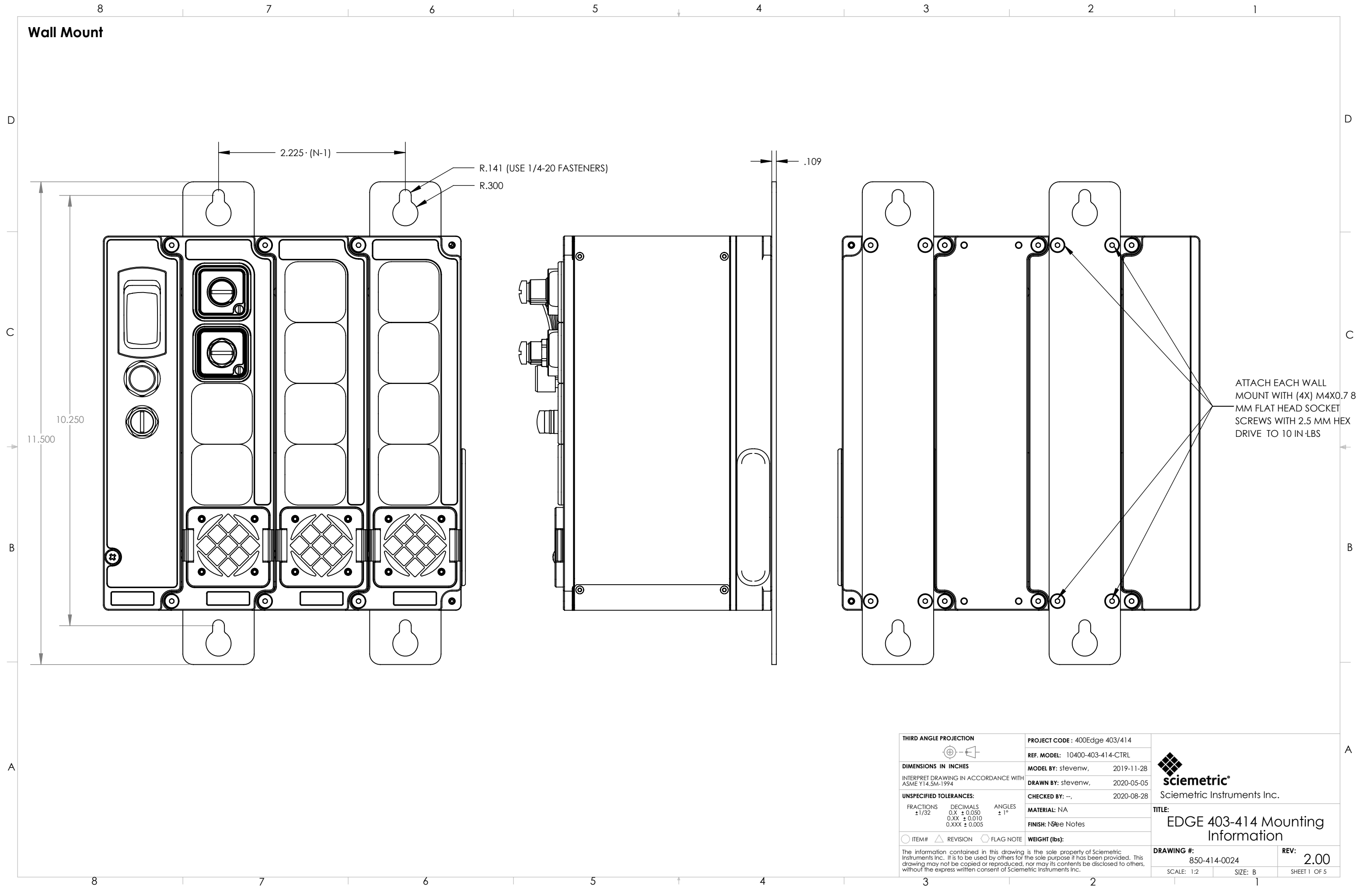

Sheet Template: B_size-11-sciemetric-SW DWG Sheet_R6.sldprt

| | | | |
|---|--|--|--|
| THIRD ANGLE PROJECTION | | PROJECT CODE: 400Edge 403/414 | |
| DIMENSIONS IN INCHES INTERPRET DRAWING IN ACCORDANCE WITH ASME Y14.5M-1994 | | REF. MODEL: 10400-403-414-CTRL | |
| UNSPECIFIED TOLERANCES: FRACTIONS ±1/32 DECIMALS 0.X ± 0.050 ANGLES ± 1° 0.XX ± 0.010 0.XXX ± 0.005 | | MODEL BY: stevenw, 2019-11-28 DRAWN BY: stevenw, 2020-05-05 CHECKED BY: -, 2020-08-28 | |
| ○ ITEM# △ REVISION ◻ FLAG NOTE | | MATERIAL: NA FINISH: See Notes | |
| The information contained in this drawing is the sole property of Sciometric Instruments Inc. It is to be used by others for the sole purpose it has been provided. This drawing may not be copied or reproduced, nor may its contents be disclosed to others, without the express written consent of Sciometric Instruments Inc. | | WEIGHT (lbs): | |
| | | TITLE: EDGE 403-414 Mounting Information | |
| | | DRAWING #: 850-414-0024 REV: 2.00 | |
| | | SCALE: 1:2 SIZE: B SHEET 1 OF 5 | |



EDGE 403/414 ACCESSORIES

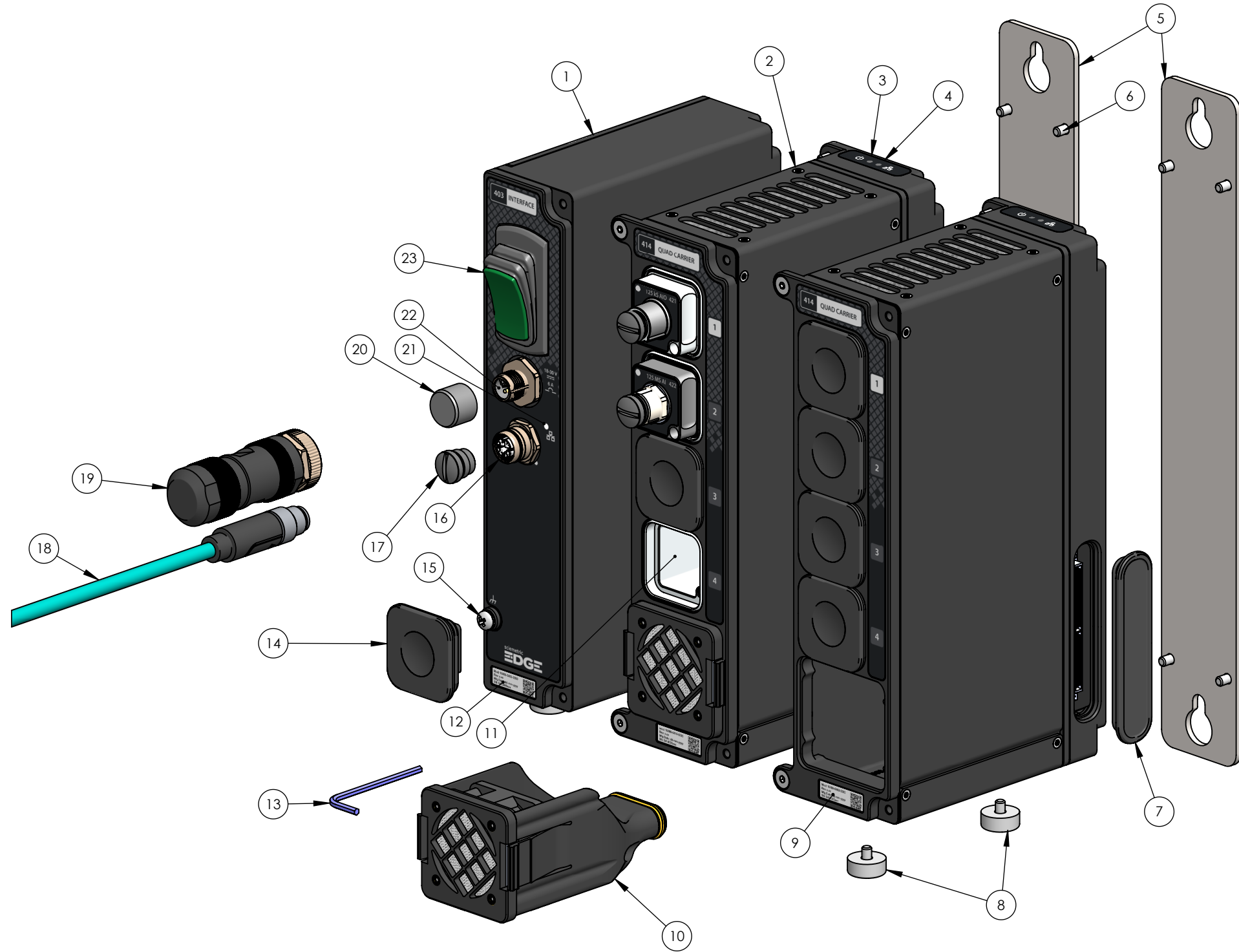

| | | | |
|---|--|---|---|
| THIRD ANGLE PROJECTION | | PROJECT CODE : 400 REF. MODEL (REV): 850-403-414-CTRL (2.00) | Sciometric Instruments ULC |
| DIMENSIONS IN INCHES INTERPRET DRAWING IN ACCORDANCE WITH ASME Y14.5M-1994 | | MODEL BY: stevenw, 2019-11-28 DRAWN BY: stevenw, 2020-05-05 CHECKED BY: --, 2020-08-28 | |
| UNSPECIFIED TOLERANCES: FRACTIONS ±1/32 DECIMALS 0.X ± 0.050 ANGLES ± 1° 0.XX ± 0.010 0.XXX ± 0.005 | | MATERIAL: NA FINISH: NA | DRAWING #: 850-414-0024 SCALE: 1:2 SIZE: B SHEET 3 OF 5 |
| ○ ITEM# △ REVISION ◻ FLAG NOTE | | WEIGHT (lbs): | REV: 2.00 |

Sheet Template: B_size-In-sciometric-SW DWG Sheet_R6.sldprt

