

BUMPER FEET LOCATIONS  
 4X #6-32  
 0.75" SCREW LENGTH CLEARANCE

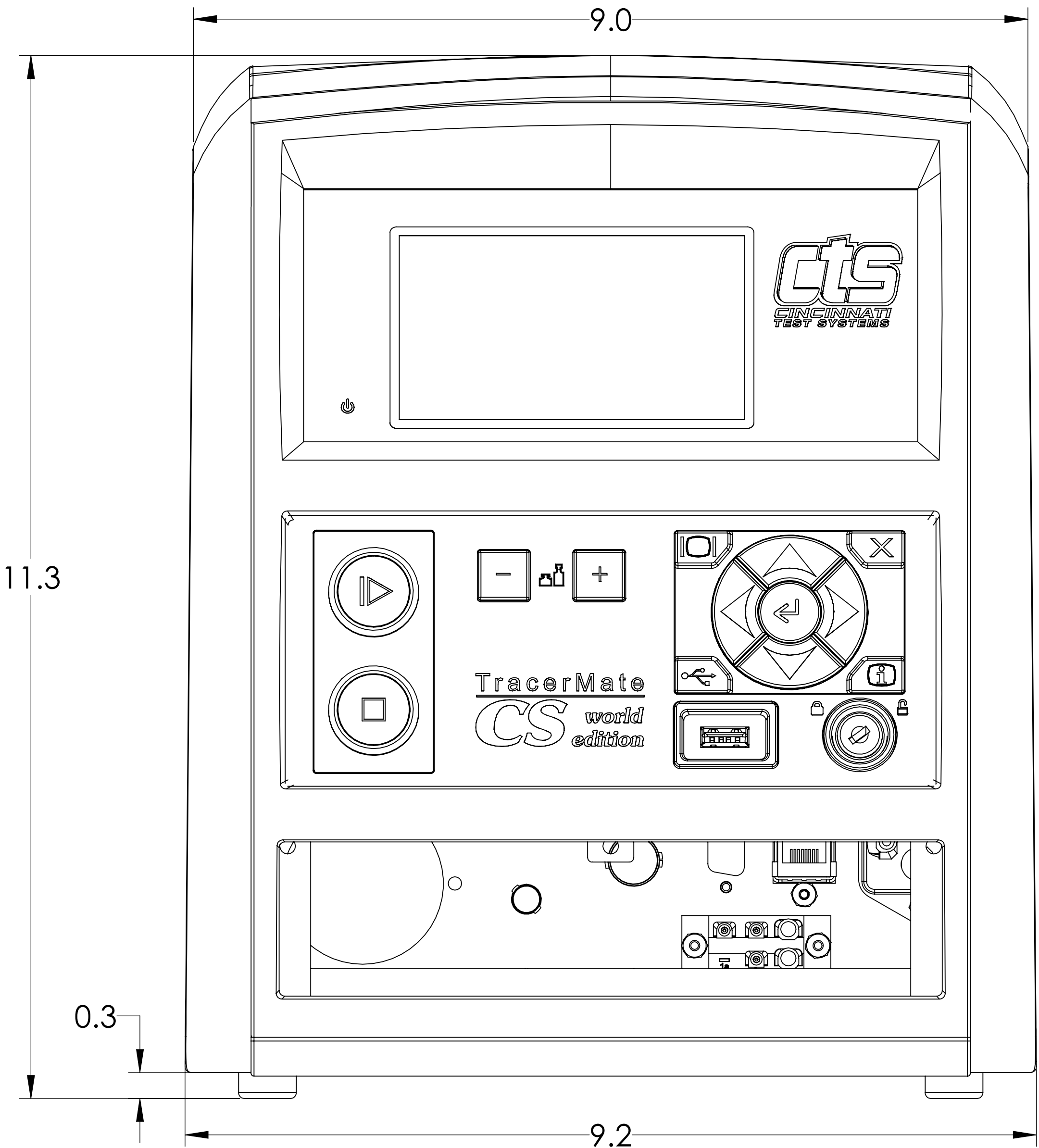

DESCRIPTION: Bose Assembly - Charge Station (CS)	
MATERIAL: -	
FINISH: -	
QUANTITY: -	HEAT TREAT: -
FILE LOCATION: -	

UNLESS OTHERWISE SPECIFIED  
 BREAK ALL SHARP CORNERS

TOLERANCES:  
 1 PLACE DECIMAL ± .050" [1.27mm]  
 2 PLACE DECIMAL ± .010" [0.25mm]  
 3 PLACE DECIMAL ± .003" [0.05mm]  
 ANGULAR DIMS ± 0' 30"

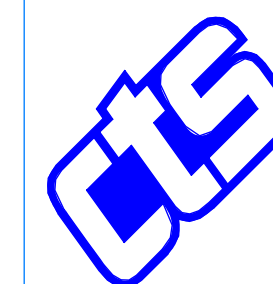

✓ INDICATES 125  
 500 MAXIMUM FINISH REQ'D ON SURFACES WITHOUT A SYMBOL

DRILLED AND COUNTERBORED HOLE DIAMETERS:  
 -.005" / +.015" [-0.13mm / +0.4mm]

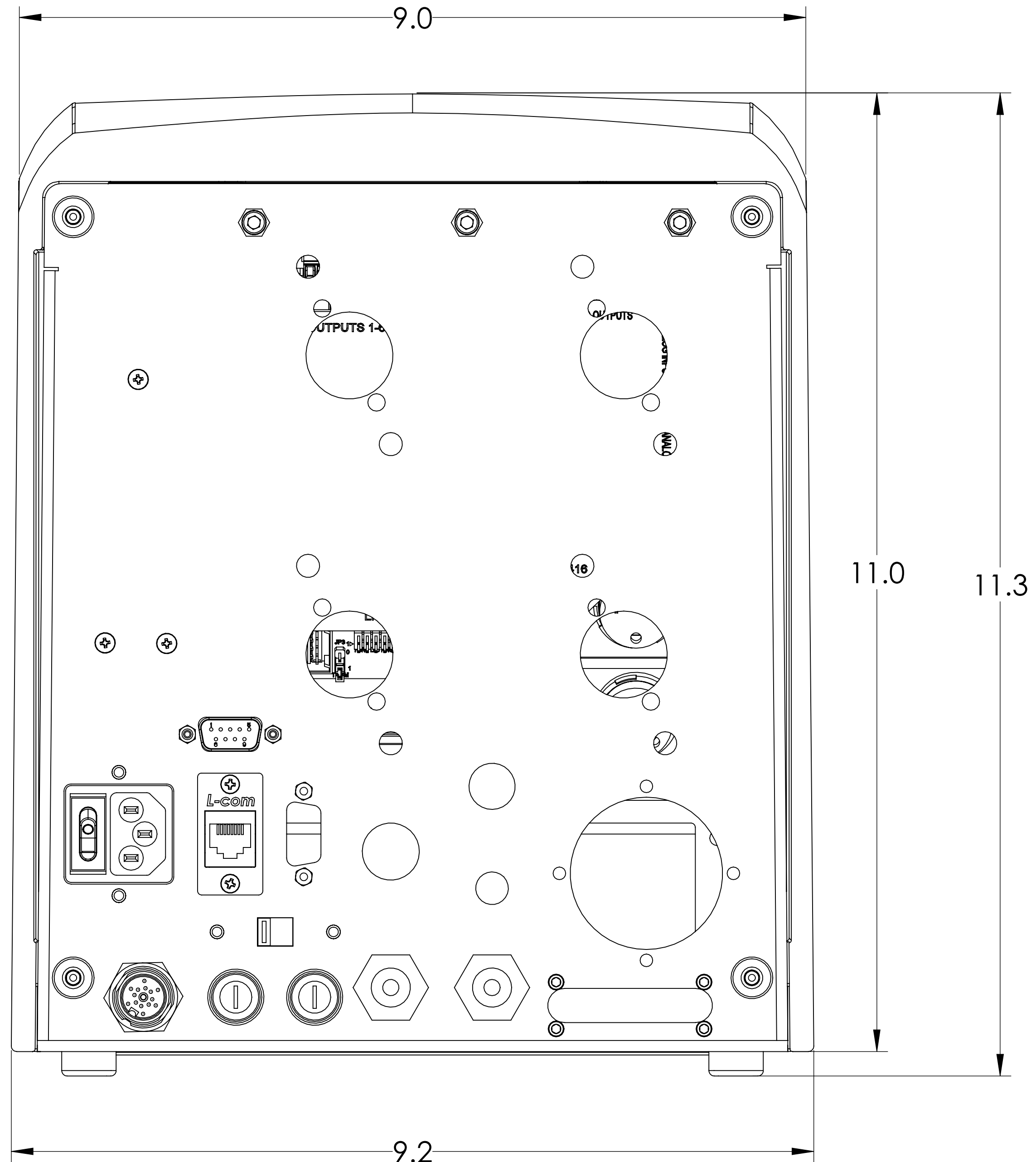
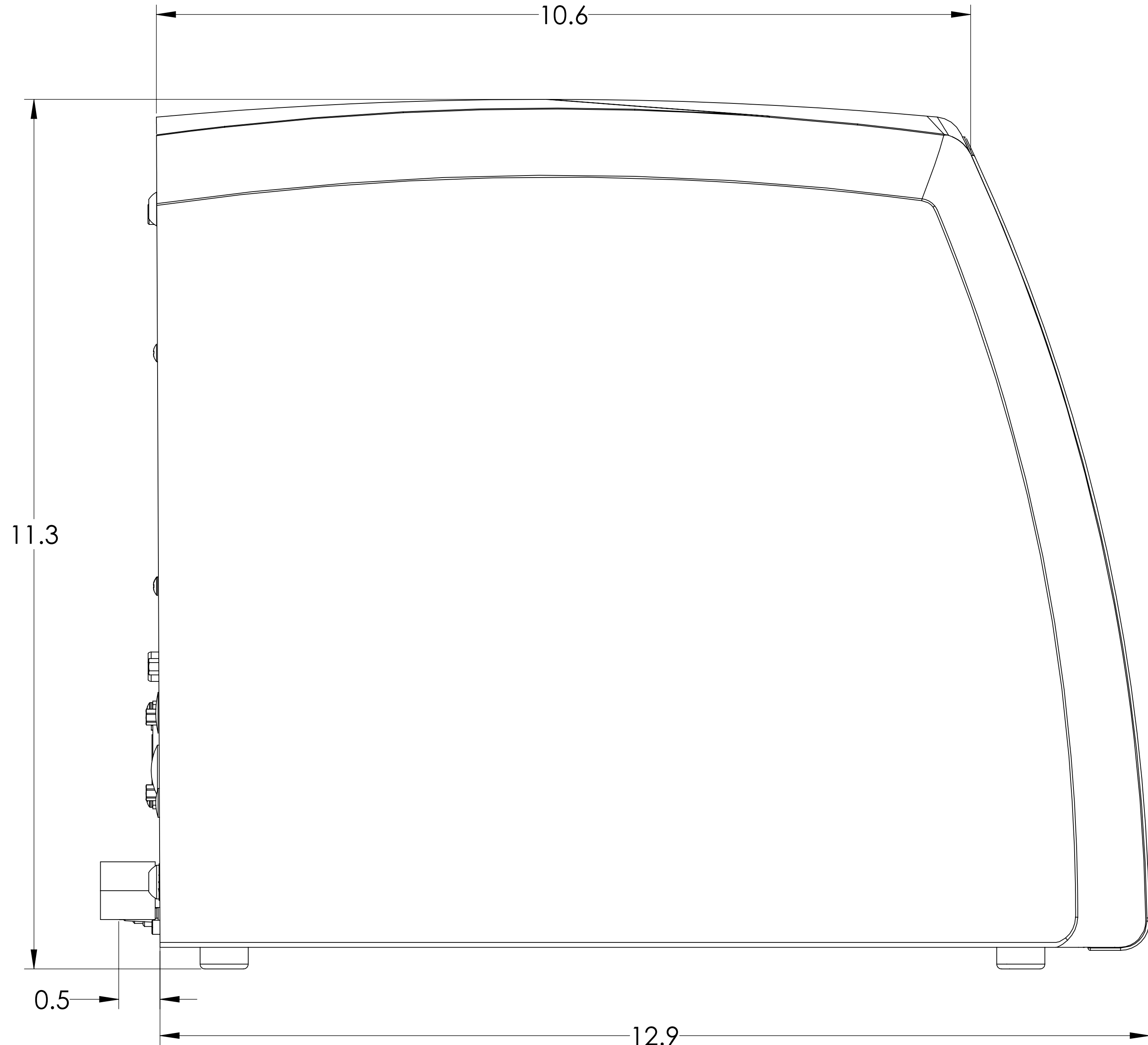

<b>CINCINNATI TEST SYSTEMS</b> 5555 DRY FORK RD., CLEVELAND, OH 45002	
CUSTOMER: CTS R&D	
TITLE: Assy,CTS,A12-538	
SIZE: D	DATE: 9/8/2011
DWG NO.:	A12-538
SCALE: 1:1	SHEET 6 OF 7

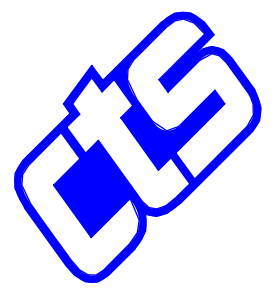

DESCRIPTION: <b>Bose Assembly - Charge Station (CS)</b>		UNLESS OTHERWISE SPECIFIED BREAK ALL SHARP CORNERS				 5555 DRY FORK RD., CLEVELAND, OH 45002	
MATERIAL: -		TOLERANCES: 1 PLACE DECIMAL ± .050" [1.27mm] 2 PLACE DECIMAL ± .010" [0.25mm] 3 PLACE DECIMAL ± .003" [0.05mm] ANGULAR DIMS ± 0° 30'		SolidWorks		CUSTOMER: CTS R&D	
FINISH: -		INDICATES 500 MAXIMUM FINISH REQ'D ON SURFACES WITHOUT A SYMBOL		TITLE: Assy,CTS,A12-538		SIZE: DATE: DWG NO.: D 9/8/2011 A12-538	
QUANTITY: HEAT TREAT: -		DRILLED AND COUNTERBORED HOLE DIAMETERS: -.005" / +.015" [-0.13mm / +0.4mm]		CHECKED BY: -		SCALE: 1:1 SHEET 7 OF 7	
FILE LOCATION: -				DRAWN BY: TAB		REV: A	

Tuesday, March 20, 2012