

Sciometric EDGE 431

4 Channel, 5V Digital I/O Module



Product Specifications

Flexible 5 V Digital I/O Module

Packed with configurable logic blocks including counters, comparators and programmable pulse generators, the Sciometric EDGE 431 is a intelligent digital I/O device. Its high-speed and galvanically isolated channels as well as sensor power supply make the 431 a stand-alone digital signal analyzer in a single, compact package.

Highlights

- On board 32 bit processor with real time operating system
- Stand-alone operation for measurement, control, signature analysis and data storage
- 4 channels, each can be assigned as input or output
- Galvanically isolated to eliminate ground loop issues
- 5 V 200 mA DC sensor supply
- Supply and outputs short circuit protected
- Digital filter for noise suppression
- Shares trigger with other System 400 modules across carrier synchronization bus lines
- Supports SENT protocol data decoding
- Option for low pass analog filter for noise suppression
- Counters, comparators, arbitrary pulse generators, pulse gap detection
- Routing of data in real time to other modules



Sciometric EDGE 431

Applications:

- ✓ Data collection of 5 V quadrature encoder signals
- ✓ Collection and decoding of SENT sensor signals
- ✓ Triggering other System EDGE 400 modules
- ✓ General purpose 5 VTTL I/O event logging and control
- ✓ Serial protocol analyzer/generator

The Sciometric EDGE platform

Sciometric EDGE is a universal industrial analytics platform to help you perfect your process in record time. This distributed data analytics system removes barriers to collecting data, driving productivity improvements and cost savings.

The platform performs digital signal processing and signature analysis to offer in-depth insight into the performance, reliability and repeatability of a broad range of applications. Processing, analytics and control functions are remotely configurable, giving you a centralized management of your distributed operations. It provides industrial operations with a sophisticated, exciting, new way to monitor a process, perform real-time pass/fail control, and gain the visibility needed to optimize and control the overall process.

Overview

The Sciometric EDGE 431 module has a digital front end, a high speed logic digital processing block and an on-board processor as shown below. The digital I/O front end is galvanically isolated from the rest of the system for noise suppression and the elimination of ground loops. It includes input protection, input or output selection, output drive, per-channel low pass filtering and an isolated 5 V supply with short circuit and overload protection.

The high speed digital logic provides an input edge filter, SENT data collection, output control and routing between synchronization bus lines and the digital front end. Processed signals such as SENT decoding can be directly transferred to other modules through the synchronization bus.

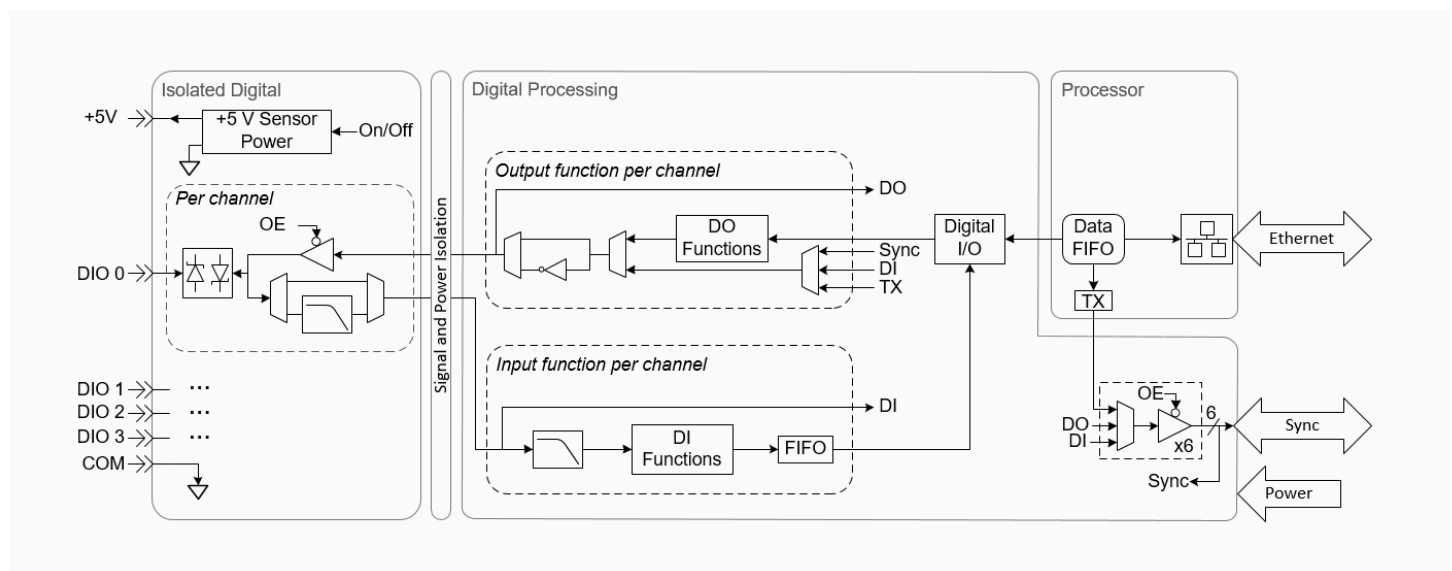

Technical Specifications

GENERAL

- Dimensions (HxWxD): 32 mm x 32 mm x 128 mm
- Connector: M12 8-pin A-code receptacle, max pin voltage 30 VDC, 24 VAC
- LED status indicator: Boot sequence, connection status, errors, etc.
- Internal temperature: 0 °C ... 70 °C
- Operating temperature: see carrier datasheet
- Ingress protection: IP65 when installed, IP20 otherwise
- Fastener screw torque: 2-4 in-lbs
- Humidity: 10 to 90% RH, non-condensing (IEC 60068-2-56)
- Shock: 150 m/s² per IEC 60068-2-27 Table A.2
- Vibration: IEC 60068-2-65 spectrum A.1 Category 3
- Pollution degree: 2 max
- Maximum altitude: 2000 m
- Weight: 132 g
- Approvals: CE, cNEMKOus

PROCESSOR

- CPU: 32 bit, 533 MHz
- Real Time Operating System: QNX™
- Storage: 512 MB SSD
- Memory: 512 MB DRAM
- Communications: EtherNet/IP (many types through optional gateway)
- Functions: Any Sciometric EDGE application, measurement, control, signature analysis and data storage

EXTERNAL 5 VDC POWER SUPPLY FOR SENSORS

- Voltage: + 5 VDC
- Ripple: 20 mV (500 kHz bandwidth)
- Regulation: 4.75 to 5.5 VDC
- Current: 200 mA max
- Short circuit protection: Indefinite
 - Other I/O channels function with up to one output channel shorted. The sensor power supply voltage will be impacted with more than one output channel shorted.
- Short circuit detection: Yes
- Overload conditions greater than 240 ms are reported to the system. Power is cycled 740 ms off, 240 ms on, until the overload condition is removed.
- Voltage Protection: -0.3 V to +28 V @ 1 mA
- Control: On/off controlled by software

DIGITAL I/O

Channels: General

- Number of channels: 4
- Set up as digital input, output
- Isolation: Digital I/O are isolated from system as a group and connected to the 5 VDC supply
- Isolation voltage: 30 V

Channels: Enabled as Inputs

- Input type:
 - Single-ended 5 V digital logic
 - SENT input signal conditioning with S/W enable per channel
 - Open collector or relay contact using SENT conditioning with internal pull-up resistor
- Input Digital Filter: Configurable single pole digital low pass filter time constant: 20 ns to 335 ms
- Input functions:
 - Digital input on/off state
 - SENT decode of fast channels and slow data (channel 0)
 - 32 bit Counter: Rise edge, falling edge, rising and falling edge, quadrature, programmable reset functions (channel 0)
 - Pulse gap detection
 - Extra pulse detection
- Routing to synchronization bus:
 - Input state for triggering and other uses
 - Live SENT fast channel value
 - Live counter value relative and absolute
- Pull-up resistor: 51 k Ω enabled with SENT input filter
- Hysteresis: 100 mV min
- High level input voltage: 3.5 V min
- Low level input voltage: 1.5 V max
- High level input current: 50 μ A max (SENT input filter off)
- Low level input current: -15 μ A max (SENT input filter off)
- Max input frequency: 50 MHz
- Sample rate: 50 MS/s divided by n, where n = 1, 2, 3,..... to 65535
- Over voltage protection: \pm 30 VDC

Channels: Enabled as Outputs

- Type: Single-ended 5 V, output mode is tri-state when output is disabled
- Output functions:
 - Static digital on/off control
 - Invert or not
 - Routed from synchronization bus line
 - Comparator sourced from another channel or module (i.e. trigger when another counter is > set value)
 - Arbitrary pulse generator (40 ns resolution)
- Voltage output high: > 4.5 VDC
- Voltage output low: < 0.3 VDC
- Source current: 25 mA
- Sink current: 15 mA
- Short circuit protection: Indefinite
 - Note: Other channels function with up to one output channel shorted. More than one output channel shorted at a time impacts the power supply voltage, which can affect operation of remaining channels.
- Short circuit current: 50 mA minimum, 75 mA typical, 100 mA maximum
- Over voltage protection: \pm 30 VDC
- Max frequency: 10 MHz

INTERNAL CALIBRATION AND DIAGNOSTICS

- Sensor power overcurrent status
- Internal measurements:
 - Module input power supply voltage and current
 - Processor supply voltage and current
 - Internal temperature

One Tool for Management, Setup and Analysis

Sciometric Studio offers comprehensive capabilities for monitoring and control of industrial applications. Manage Sciometric EDGE Systems through discovery, sensor calibration, application deployment, and software updates. Manage applications through configuration of tasks, features, parameters and variants. Leverage continuous improvement through data-driven insight with analytics such as feature, waveform and image trending, correlations and statistical reports.

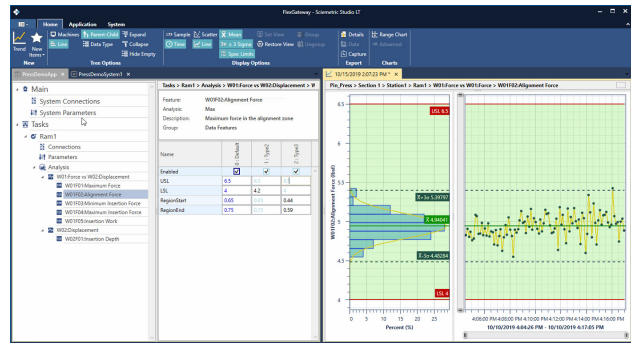

Mounting Information

The Sciometric EDGE 431 must be installed in a 412 Dual Carrier. Please see the 412 datasheet for additional information and specifications.

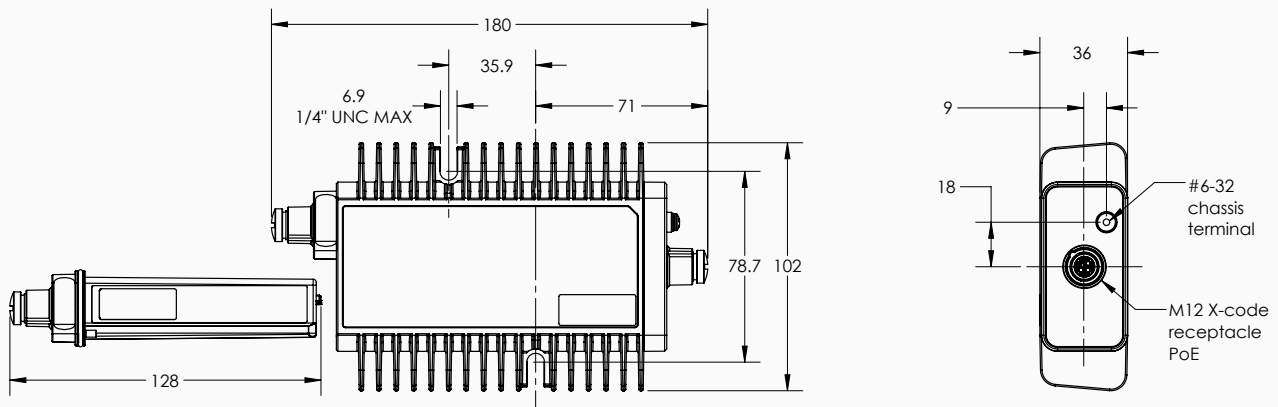

Ordering Information

Module

Item	Part number	
Sciometric EDGE 431 module	10400-0431-0M12	

Accessories

Mounting

Refer to System 400 carrier datasheet(s) for mounting options

Connectors

Item	Part number	
Male A-code 8-pin – M12 field wire-able	10400-AX0A-MA08	

© 2019 Sciometric, Sciometric EDGE and any related marks are trademarks or registered trademarks of Sciometric Instruments Inc. All other trademarks are the property of their respective companies. All rights reserved. No part of this publication may be reproduced without the prior written permission of Sciometric Instruments Inc. While every precaution has been taken in the preparation of this document, Sciometric Instruments ULC. assumes no responsibility for errors or omissions. Neither is any liability assumed for damages resulting from the use of the information contained herein. Specifications subject to change without notice.



1.877.931.9200
inquiries@sciometric.com

REV 1, OCTOBER 2019 – PRINTED IN CANADA